

SCHMEISER[®]
4-BAR FOLDING
TILL AN' BEDDER

ASSEMBLY & PARTS
MANUAL

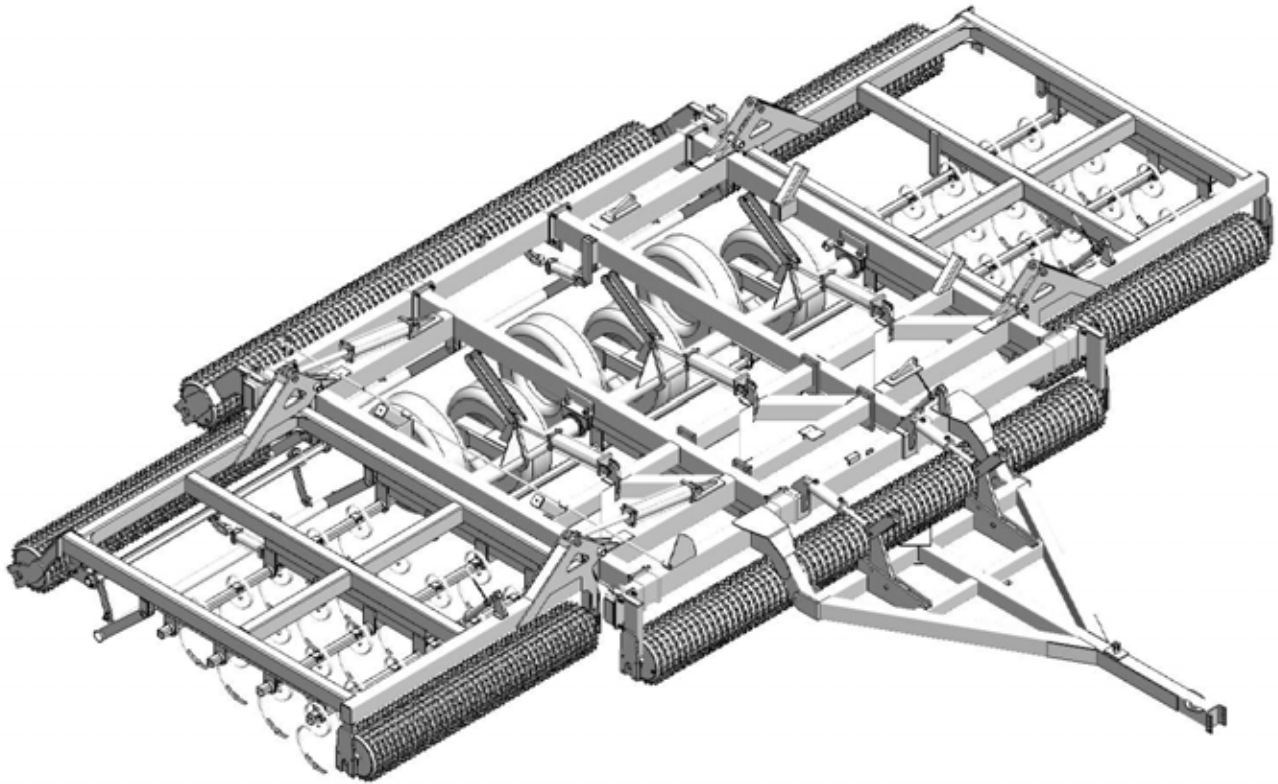

T.G. SCHMEISER CO., INC.
P.O. BOX 1047 FRESNO, CA. 93714
(559) 268-8128 FAX (559) 268-3279
www.tgschmeiser.com

VERSION 1.4
04-2011

INTRODUCTION

Your Schmeiser Till An' Bedder is designed to give you many years of dependable service. This manual has been prepared to instruct you in the safe and efficient operation of this machine. Read and study it thoroughly. Follow all instructions carefully.

Should your Till An' Bedder require replacement parts, go to your Schmeiser dealer. Always order genuine Schmeiser replacement parts.

It is important that you complete and send in your Warranty Card because it is not valid unless it is on file at Schmeiser. If you need information not contained in this manual, contact your Schmeiser dealer.

Space has been provided below for you to record the model number and serial number of your Till An' Bedder. Be sure to bring this information with you to your dealer when ordering parts or attachments for your Till An' Bedder.

Thank you for buying a Schmeiser Till An' Bedder.

SERIAL NUMBER _____

MODEL NUMBER _____

DATE PURCHASED _____

DEALER NAME _____

TABLE OF CONTENTS

Introduction	2
Table of Contents.....	3
Safety Sheet.....	4
4-Bar Folding Till An' Bedder Set Up Instructions.....	5
4-Bar Folding Till An' Bedder Specifications.....	7
4-Bar Folding Till An' Bedder Assembly	8
4-Bar Folding Till An' Bedder Pull Frame and Hitch Assembly	10
4-Bar Folding Till An' Bedder Hinge Assembly.....	12
S-Tine Assembly	13
S-Tine Tie Clamp Assembly.....	14
Wheel Axle Bearing Assembly.....	15
4-Bar Folding Till An' Bedder Wheel Axle Assembly.....	16
Spindle and Hub Assembly.....	17
FTB4 Front Roller Assembly.....	18
FTB4 Rear Roller Assembly.....	19
FTB4 Main Frame Leveling Pipe Assembly.....	20
FTB4 Wing Leveling Pipe Assembly.....	21
Hydraulic Diagram for FTB4 Wheel Axle & Pull Frame 24 Ft. Units.....	22
Hydraulic Diagram for FTB4 Wheel Axle & Pull Frame 25Ft.through 30Ft.Units..	23
Hydraulic Diagram for 4-Bar Folding Till An' Bedder Wings 24 Ft.Units.....	24
Hydraulic Diagram for 4-Bar Folding Till An' Bedder Wings 25Ft.through 30Ft...	25
Hydraulic Diagram for 4-Bar Folding Till An' Bedder Rock Shaft.....	26
Limited Warranty.....	27
Maintenance and Repair Record.....	28

SAFETY

The safe operation of any machinery is an important concern to farmers and manufactures. There are obvious and hidden potential hazards involved in the operation of this implement. Carefully read and follow all safety precautions before operation. Serious injury or death may occur unless care is taken to insure the safety of both the operator and any other persons in the area.

1. Never permit anyone to ride on or walk beside the implement when moving.
2. Never permit anyone to ride on tractor when implement is being moved.
3. When performing operating functions, never allow anyone to be near the implement or the tractor.
4. Do not enter tractor when tractor is moving. Avoid serious injury or death from contact with rotating tires. Enter and exit the tractor only when it is completely stopped.
5. Be sure of water, gas, sewer, or electric line locations before operating implement.
6. When in transport, use accessory lights and devices for adequate warning to operators of other vehicles. Comply with all Federal, State and local laws when traveling on public roads.
7. Use "Slow Moving Vehicle" emblem for warning vehicles approaching from the rear.
8. When transporting, remember that the implement may be wider than your tractor and extreme care must be taken to allow for safe clearance.
9. Never allow inexperienced or untrained personnel to operate the implement or tractor without supervision.
10. When using compressed air to clean implement, wear safety glasses.
11. Check all fasteners for tightness or damage before and after operation. Repair immediately if required.
12. Store implement in a stable position. Insure that safety stands are extended and locked in place before detaching from tractor.

4-BAR FOLDING TILL AN' BEDDER SET UP INSTRUCTIONS

THE FOLLOWING TOOLS ARE NEEDED:

1. Overhead hoist or forklift.
2. Impact gun or socket wrench with 3/4", 1-1/8", 1-5/16" and 1-1/2" sockets.
3. 3/16" allen wrench.
4. Pry bar
5. 14" tapered drift punch.
6. (6) Heavy duty stands ("horses") – approx. 30" tall, 100" long, approx. 3000 lbs weight capacity.

PROCEDURE:

1. Select a smooth, level piece of ground of approximately 50' x 50' to assemble the SCHMEISER Folding Till An' Bedder. Put stands about 10 feet apart. Place Front Frame (item 5 on page 11) on the stands with pull arms facing in the direction it will be pulled. Do not install Pull Frame yet as this will obstruct access to main body of machine.
2. Place H-Frames behind the front frame. Refer to assembly drawing on page 9 for details and correct placement. Place Center Frame between two H-Frames. Insure that Flow divider mounting pad faces forward. Connect Center Frame and H-Frames using 1" x 2-1/2" NC Cap Screws with Lock Washers and Hex Nuts. Do not tighten bolts.
3. Connect H-Frames and Front frame using 7/8" NF U-Bolts with Lock Washers and Hex Nuts. Insure that center of Center Frame lines up with center of the Front Frame. Do not tighten hex nuts.
4. Place Rear Roller Frame behind H-Frames. Insure that the center of the Rear Frame is aligned with the center of the Front Frame. Mount Rear Frame to the H-Frames using 7/8" U-Bolts with lock washers and hex nuts. Check that Front frame, Rear frame, Center Frame, and H-Frames are square. Tighten all fasteners.
5. Take the assembled Main Frame off of the stands. Place main frame S-Tine bar assembly on stands with S-Tine points facing forward. Put Wheel Axle with attached Walking Beams on the floor behind the S-Tine assembly. Legs should aim backward. Mount tires to the Walking Beams.
6. Put assembled Main Frame on top of S-Tine assembly. Insure that Mounting Brackets are lined up with S-Tine Hangers on the Main Frame. Use 3/4" x 2" NC Gr.5 Cap Screws with lock washers and hex nuts. Do not tighten bolts.
7. Using hoist, pick up Wheel Axle, align cylinder anchors on the Wheel Axle with cylinder anchors on the H-Frames. Connect Wheel Axle and H-Frames using 1" Round U-Bolts and Bearing Cradle Assemblies with Lock Washers and Hex Nuts (refer to page 15 for details).
8. Place wings on each side of H-Frames. See assembly drawing on page 9 for correct placement. Connect wings to H-Frames using Hinge Pins with 3/8" x 3" NC Cap Screws and Hex Nuts.
9. Mount both left and right Front Roller Arms to Front Frame as shown on page 18. Insure that the Front Roller Arm top plates are just to the inside of the 1/2" square stops on the front cross bar. Also insure that the bearing mounting plates face out. Refer to the drawing on page 18 for proper installation. Install 7/8" Square U-bolts and 3/4" x 10" with lock washers and hex nuts, hand tighten only.

10. Mount both left and right Rear Roller Arms to rear cross bar of Main Frame as shown on page 19. Insure that the Rear Roller Arm top plates are just to the inside of the 1/2" square stops on the rear cross bar. Also insure that the bearing mounting plates face out. Install 7/8" Square U-bolts and 3/4" x 10" with lock washers and hex nuts, hand tighten only. Refer to the drawing on page 19 for details.
11. *Attach 4" x 16" Hydraulic Cylinders (see drawing on page 9 item # 13) with rod ends facing Wheel Axle. Install Cylinder Lockout Bars for 4" x 16" Hydraulic Cylinders. Refer to the drawing on page 9.
12. * Attach rod ends of 4" x 20" Hydraulic Cylinders to the wings with 1" x 8" NC Gr.8 Bolts with Lock Washers and Hex Nuts. Attach other ends of cylinders to the cylinder anchors on the H-Frames using 1" Cylinder Pins with cotter pins.
13. * Mount Leveling Pipes to the wings and main frame. See drawings on pages 20 and 21 for details.
14. * Attach 2-1/2" x 8" Hydraulic Cylinders for leveling pipes with rod ends facing towards leveling pipes. See assembly drawing for details.
15. Mount all (12) 2-3/16" flange bearings onto all Ring Roller bearing shafts using a 3/16" allen wrench.
16. Mount one of the Main Frame Ring Rollers to the front of the machine using 5/8" x 2-1/2" hex bolts with flat washers, lock washers, and hex nuts. Tighten all bolts. For packing, front ring teeth should aim down. For tilling, front teeth should aim up.
17. Mount the remaining Main Frame Ring Roller to the Rear Roller Arms using 5/8" x 2-1/2" hex bolts with flat washers, lock washers, and hex nuts. Tighten all hex bolts. Once the rear roller is mounted, tighten Rear Roller Arm bolts.
18. Lift rear of unit to take the weight off of the Wheel Axle Cylinder Lockout Bars. Swing lockouts up and lower unit to the ground.
19. Mount all Wing Rollers to the Wing Frames, using 5/8" x 2-1/2" hex bolts with flat washers, lock washers, and hex nuts. Tighten all bolts. Insure that the ring teeth are aiming in the same direction on all ring rollers.
20. Mount Pull Frame to Main Frame pull arms using 1" x 7" hex bolts with nylon lock nuts. Install 3-1/2 x 8 Hydraulic Cylinders to Main Frame and Pull Frame Pivot Link and Lockout Bar as shown on page 9, using 1" x 3" hex bolts with nylon lock nuts. Install Hose Holders and connect Lead Hoses to Hydraulic Manifold and Tractor.
21. **BEFORE ENGAGING ANY HYDRAULIC CYLINDERS, INSURE THAT NO ONE IS ANYWHERE NEAR THE IMPLEMENT OR TRACTOR.** Insure that there are no overhead and/or other obstructions. All hydraulic lines must be free of debris and air and completely full of hydraulic fluid prior to field operation. Extend and retract rear leveling pipe cylinders until smooth operation is achieved. Lift and lower entire unit completely several times until all cylinders work as intended. Always raise unit fully off the ground prior to folding or unfolding wings. Take special care when unfolding wings. Fold and unfold wings until unit works smoothly.

* NOTE: 4-Bar Folding Till An' Bedder comes with all hydraulic cylinders preinstalled. Also, wings are preassembled.



Total Width	Main Frame Width	Wing Width	Total Number of Rings
24' Units	13 ft.	5 ft. 6 in.	240
25' Units	15 ft.	5 ft. 0 in.	250
26' Units	15 ft.	5 ft. 6 in.	260
28' Units	15 ft.	6 ft. 6 in.	280
30' Units	15 ft.	7 ft. 6 in.	300

Tube, Ring, and Retainer Chart

Tube Size	Ring Size (ID / OD)	Ring Part #	Retainer Size (ID - OD)	Retainer Part #
10"	13 / 17	TPP3352	10 - 16	TPP3207
12"	14 / 20	TPP3353	12 - 18	TPP3210

S-Tines and Components Quantity Chart

Ref. #	Part Number	Description	Qty.				
			24'	25'	26'	28'	30'
1.	GST-25150S	1/4" X 1-1/2" S-Tine	72	76	78	84	90
2.	GST-2CL250	2-1/2" Tool Bar Clamp	72	76	78	84	90
3.	CBNC508064	1/2" X 4" Round Head Square Neck Bolt	72	76	78	84	90
4.	LWASHER-08	1/2" Lock Washer	72	76	78	84	90
5.	HXNUT-08NC	1/2" NC Hex Nut	72	76	78	84	90
6.	GST-25150P	1/4" Standard S-Tine Point	72	76	78	84	90
7.	GST-0624BN	3/8" X 1-1/2" Elliptical Head Metric Plow Bolt w/Nut	72	76	78	84	90



<u>Ref No.</u>	<u>Part No.</u>	<u>Description</u>	<u>Qty.</u>
1.	FTB4-00A000	Pull Frame Weldment	1
2.	UBNF14128S	7/8" Square U-Bolt	24
3.	TBU-00D100	Front Linkage High Clearance Pivot Plate	2
4.	FTB4-00F100	FTB4 Main Frame (specify size)	1
5.	FTB4-00K000	FTB4 Wing Weldment - Pair (specify size)	1
6.	-----	Main Frame Ring Roller (specify unit size)	2
7.	-----	Wing Ring Roller (specify unit size)	4
8.	FTB4-00J000L(R)	FTB4 Rear Roller Arm Weldment LH and RH	2
9.	FTB4-00M100	FTB4 Wheel Axle Weldment (specify unit size)	1
10.	GWT-121614	12.5 X 16 Tire with Wheel Assembly	6 or 4
11.	FTB4-00J100L(R)	FTB4 Front Roller Arm Weldment LH and RH	2
12.	GHC-35080W	3-1/2" X 8" Welded Hydraulic Cylinder	2
13.	GHC-40160T	4" X 16" Tie Rod Hydraulic Cylinder	3 or 2
14.	GHC-40200T	4" X 20" Tie Rod Hydraulic Cylinder	4
15.	GHC-25080T	2-1/2" X 8" Tie Rod Hydraulic Cylinder	3
16.	FTB4-(00)P100	Wing Leveling Pipe Weldment (specify size) - pair	1
17.	FTB4-(00)P000	Main Frame Leveling Pipe Weldment (specify size)	1
18.	FTB-00Q500	Leveling Pipe Link for 12" Tube, 14/20 Rings	8
	TBU-00L500	Leveling Pipe Link for all other combinations	8
19.	DIK-FTB4	Depth Indicator Kit for FTB4	1
20.	GWD-416LB1	Lockout Bar for 4" X 16" Hydraulic Cylinder	3 or 2
21.	GWD-358LB1	Lockout Bar for 3-1/2" X 8" Hydraulic Cylinder	2
22.	-----	S-Tine Assembly (see page 13 for details)	varies
23.	GPN-0856SL	Hitch Lock Pin 1/2" x 3-1/2" Usable	5 or 4
24.	PMCK-43500	Seal Kit for 3-1/2" x 8" Welded Hydraulic Cylinder	
25.	PMCK-34000	Seal Kit for 4" x 16" and 4" x 20" Hydraulic Cylinders	
26.	PMCK-32500	Seal Kit for 2-1/2" x 8" Hydraulic Cylinder	

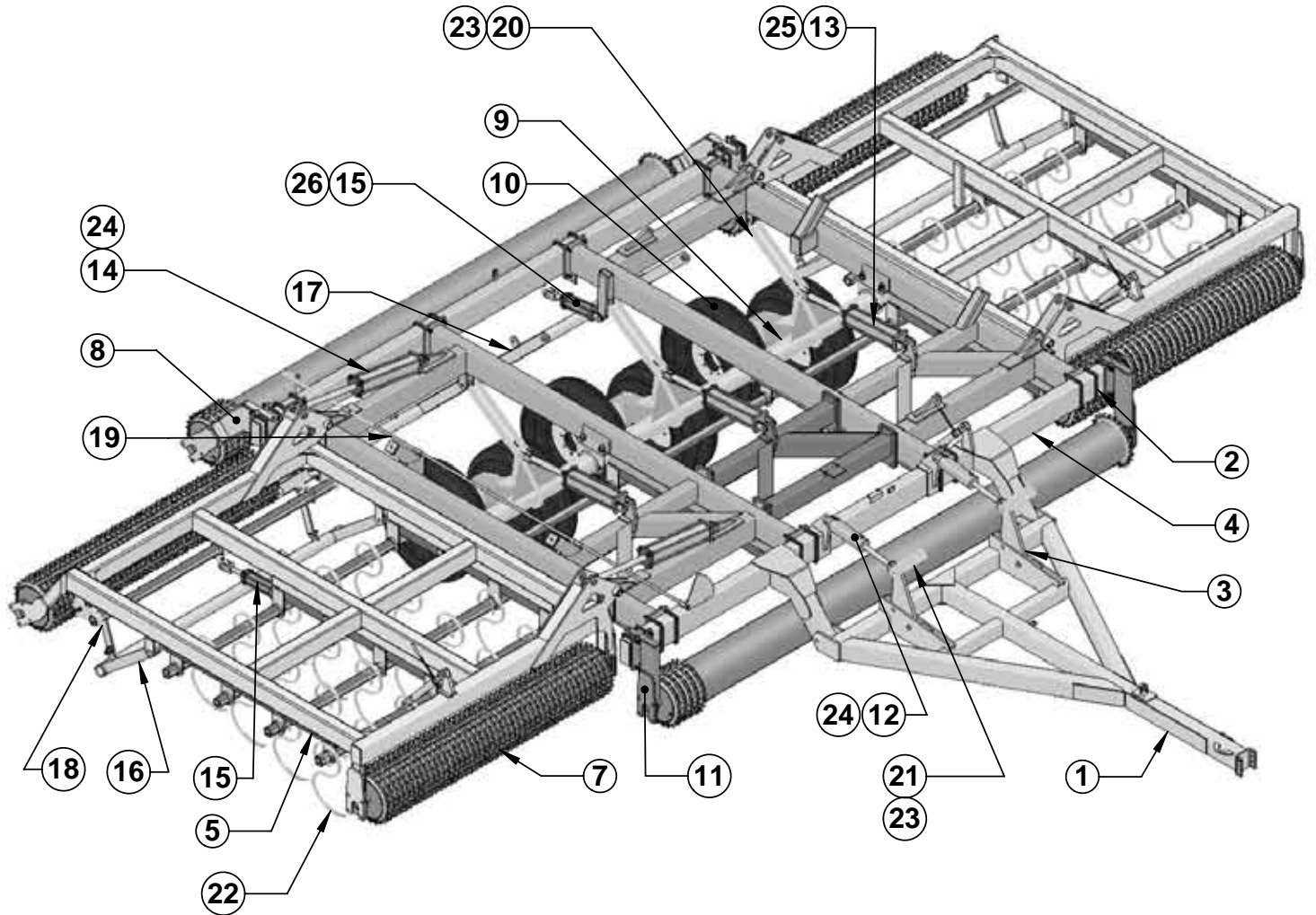

*** NOTE: ALL RINGS ON FRONT AND REAR MAIN FRAME ROLLERS ARE NOT SHOWN FOR CLARITY.**



T. G. SCHMEISER CO., INC. PULL FRAME AND FRONT FRAME ASSEMBLY

<u>Ref No.</u>	<u>Part No.</u>	<u>Description</u>	<u>Qty.</u>
1.	FTB4-00A000	Pull Frame Weldment	1
2.	-----	Main Frame Roller Tube (specify size)	2
3.	FTB4-00J100L(R)	Front Roller Arms LH and RH	2
4.	TBU-00D100	Front Pivot Plate High Clearance	2
5.	-----	Front Frame Weldment	1
6.	GHC-35080W	3.5" X 8" Welded Hydraulic Cylinder	2
7.	GWD-358LB1	3.5" X 8" Cylinder Lockout Bar	2
8.	NYNUT-16NC	1" Nylon Lock Hex Nut	6
9.	CSNC516048	1" X 3" NC Cap Screw Gr.5	2
10.	CSNC516112	1" X 7" NC Cap Screw Gr.5	2
11.	CSNC512160	3/4" X 10" NC Cap Screw Gr.5	2
12.	UBNF14128S	7/8" NF Square U-Bolt	4
13.	LWASHER-14	7/8" Lock Washer	8
14.	HXNUT-14NC	7/8" NF Hex Nut	8
15.	NYNUT-12NC	3/4" NC Nylon Lock Hex Nut	2
16.	TPP3158	2-3/16" Flange Bearing	4
17.	-----	Roller Ring (specify size)	varies
18.	FTB4-00S000	Ratchet Jack Weldment	3
19.	-----	Ring Roller Retainer (see page 7 for part numbers)	12
20.	GPN-0856SL	1/2" X 3-1/2" Usable Hitch Lock Pin	2
21.	PMCK-43500	Seal Kit for 3-1/2" x 8" Welded Hydraulic Cylinder	



T. G. SCHMEISER CO., INC. PULL FRAME AND FRONT FRAME ASSEMBLY

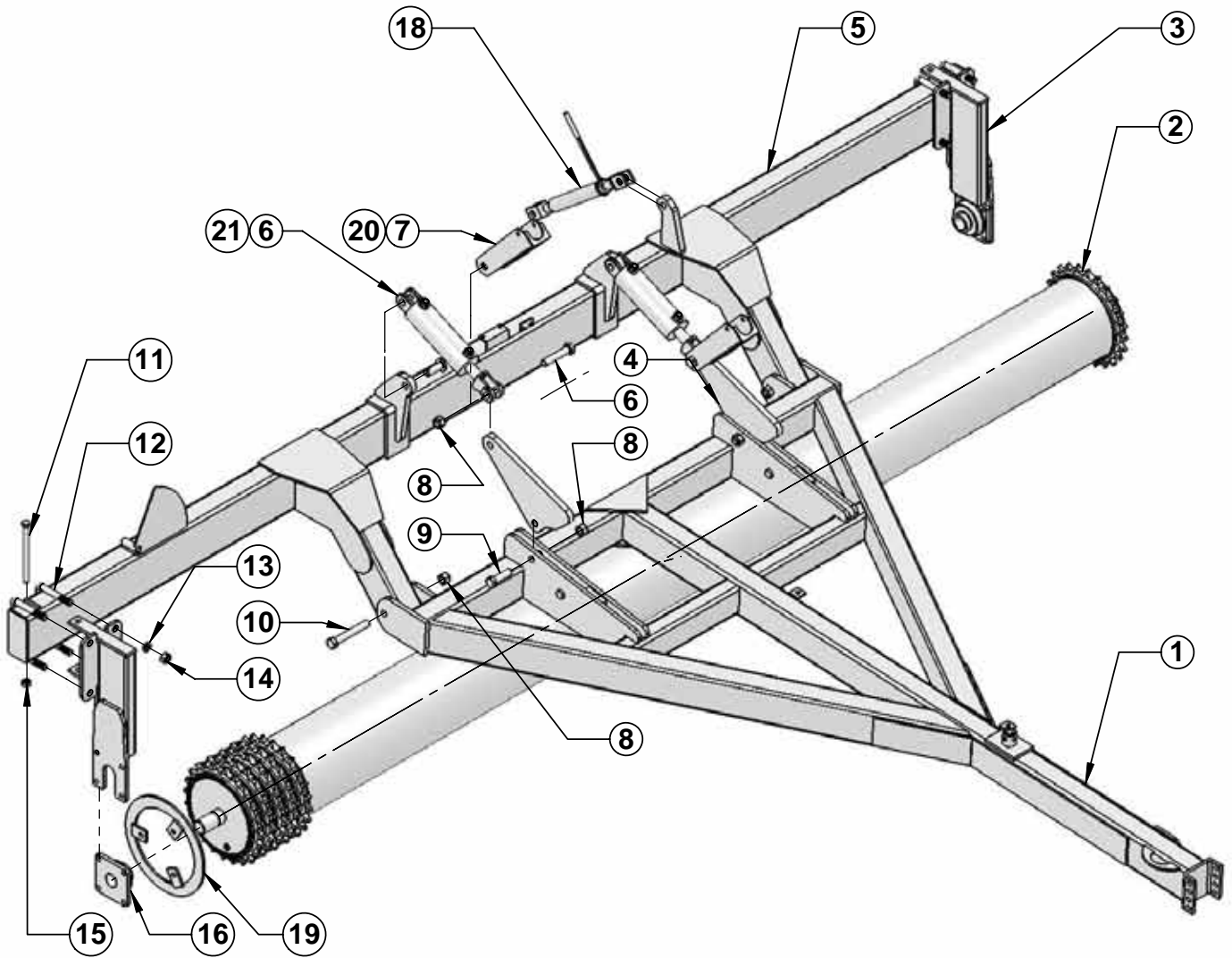

NOTE: ALL RINGS ARE NOT SHOWN FOR CLARITY

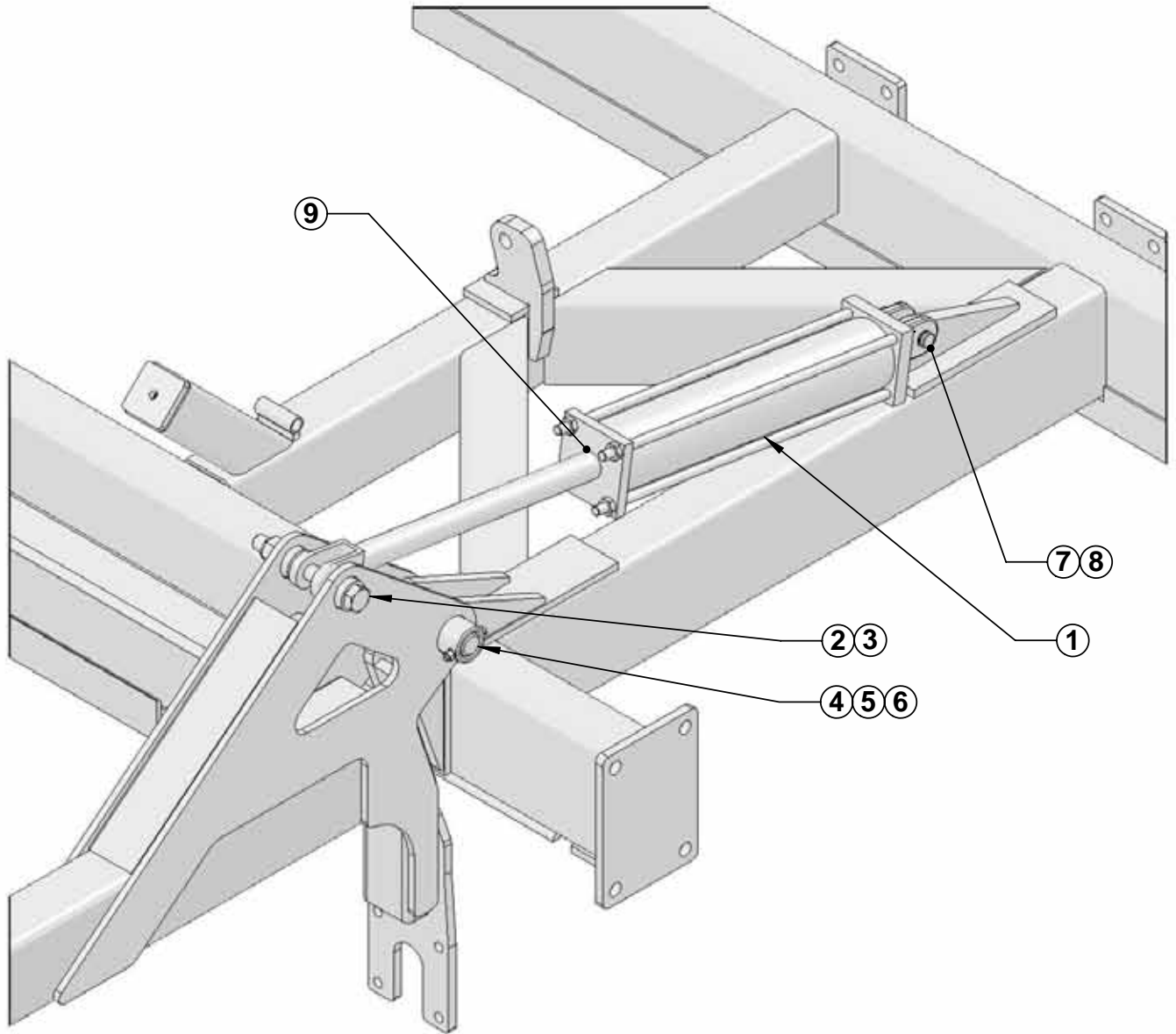

<u>Ref No.</u>	<u>Part No.</u>	<u>Description</u>	<u>Qty.</u>
1.	GHC-40200T	4" X 20" Hydraulic Cylinder	4
2.	CSNC816128	1" X 8" NC Gr.8 Cap Screw	4
3.	NYNUT-16NC	1" NC Nyloc Lock Hex Nut	4
4.	FTB4-00F600	Wing Hinge Pin	4
5.	CSNC506048	3/8" X 3" NC Gr.5 Cap Screw	4
6.	NXNUT-06NC	3/8" NC Hex Nut	4
7.	GPN-1664HC	1" X 4" Cylinder Pin	4
8.	GPN-03CLIP	5/32" X 3" Hair Pin Clip	4
9.	PMCK-34000	Seal Kit for 4" X 20" Hydraulic Cylinder	

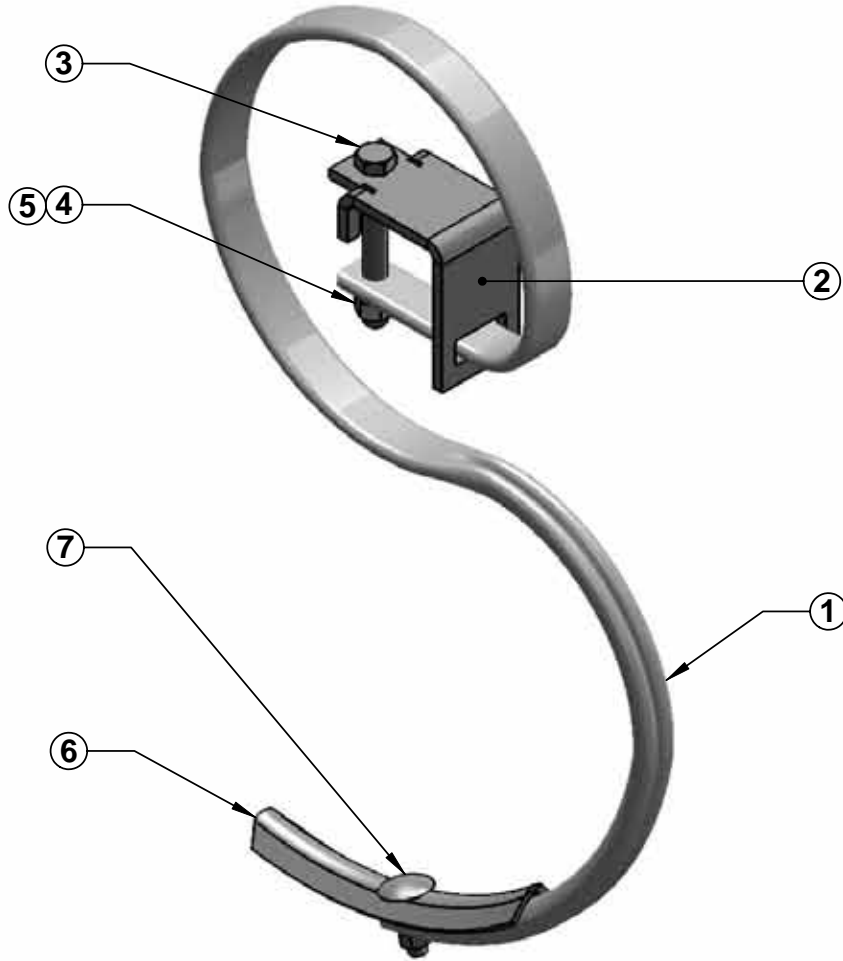

<u>Ref No.</u>	<u>Part No.</u>	<u>Description</u>	<u>Qty.</u>
1.	GST-50125S	1/2" X 1-1/4" S-Tine Std.	varies
2.	GST-2CL250	2-1/2" S-Tine Bar Clamp	varies
3.	CBNC508064	1/2" X 4" Round Head Square Neck Bolt	varies
4.	HXNUT-08NC	1/2" NC Hex Nut	varies
5.	LWASHER-08	1/2" Lock Washer	varies
6.	GST-25150P	1/4" Standard S-Tine Point	varies
7.	GST-0624BN	3/8" X 1-1/2" Elliptical Head Metric Plow Bolt w/Nut	varies

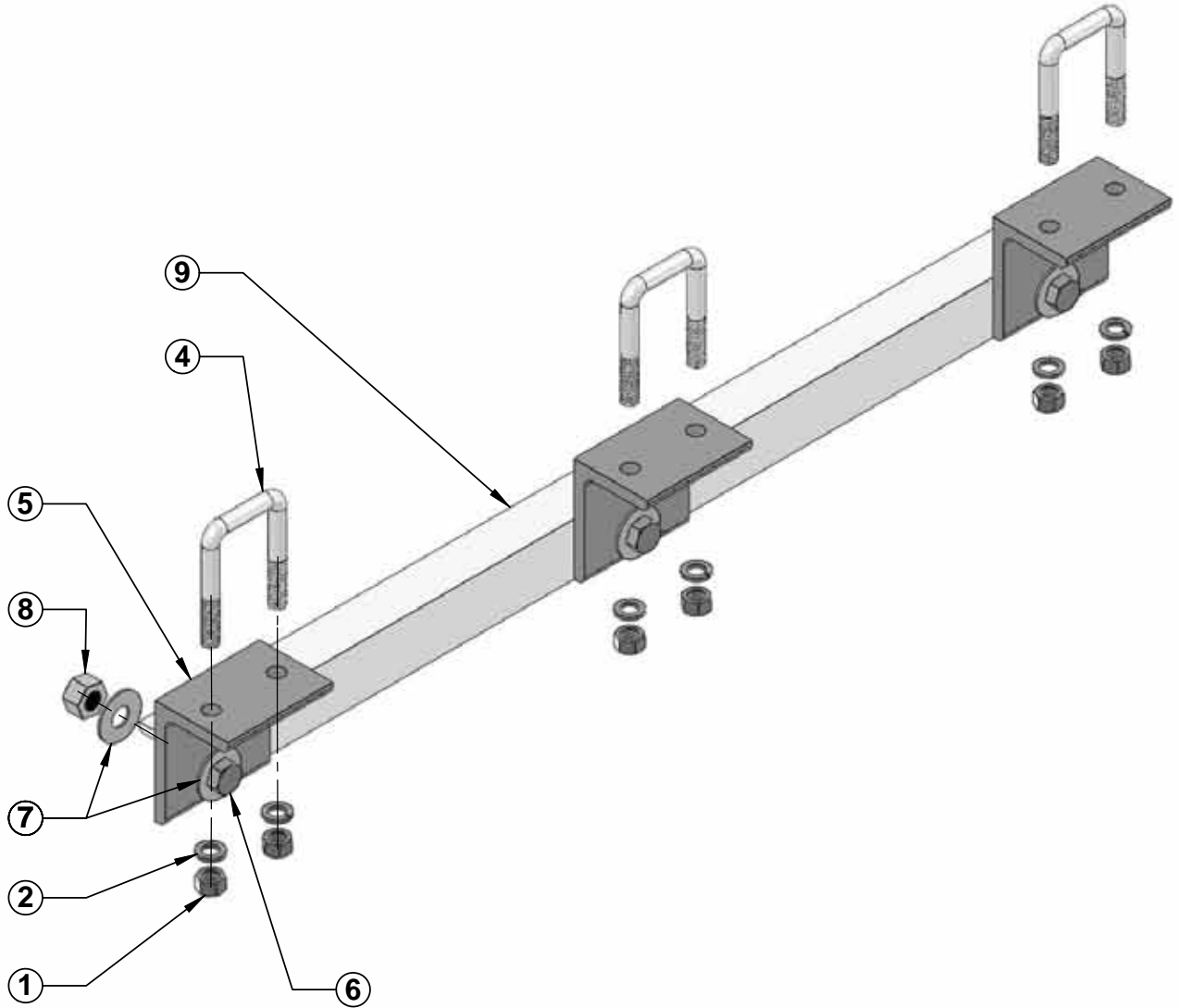

<u>Ref No.</u>	<u>Part No.</u>	<u>Description</u>	<u>Qty.per tie bar</u>
1.	HXNUT-10NC	5/8" NC Hex Nut	6
2.	LWASHER-10	5/8" Lock Washer	6
3.	SQT25W04	2-1/2" S-Tine Bar (specify size)	
4.	UBNC10X41S	5/8" X 11" NC Square Bend U-Bolt	3
5.	GPR-A50003	S-Tine Tie Clamp Bracket	3
6.	CSNC512040	3/4" X 2-1/2" NC Cap Screw Gr.5	3
7.	FWASHER-12	3/4" Flat Washer	6
8.	NYNUT-12NC	3/4" NC Nylon Lock Hex Nut	3
9.	TB4-00K402	S-Tine Tie Bar for 4-Bar Units	1

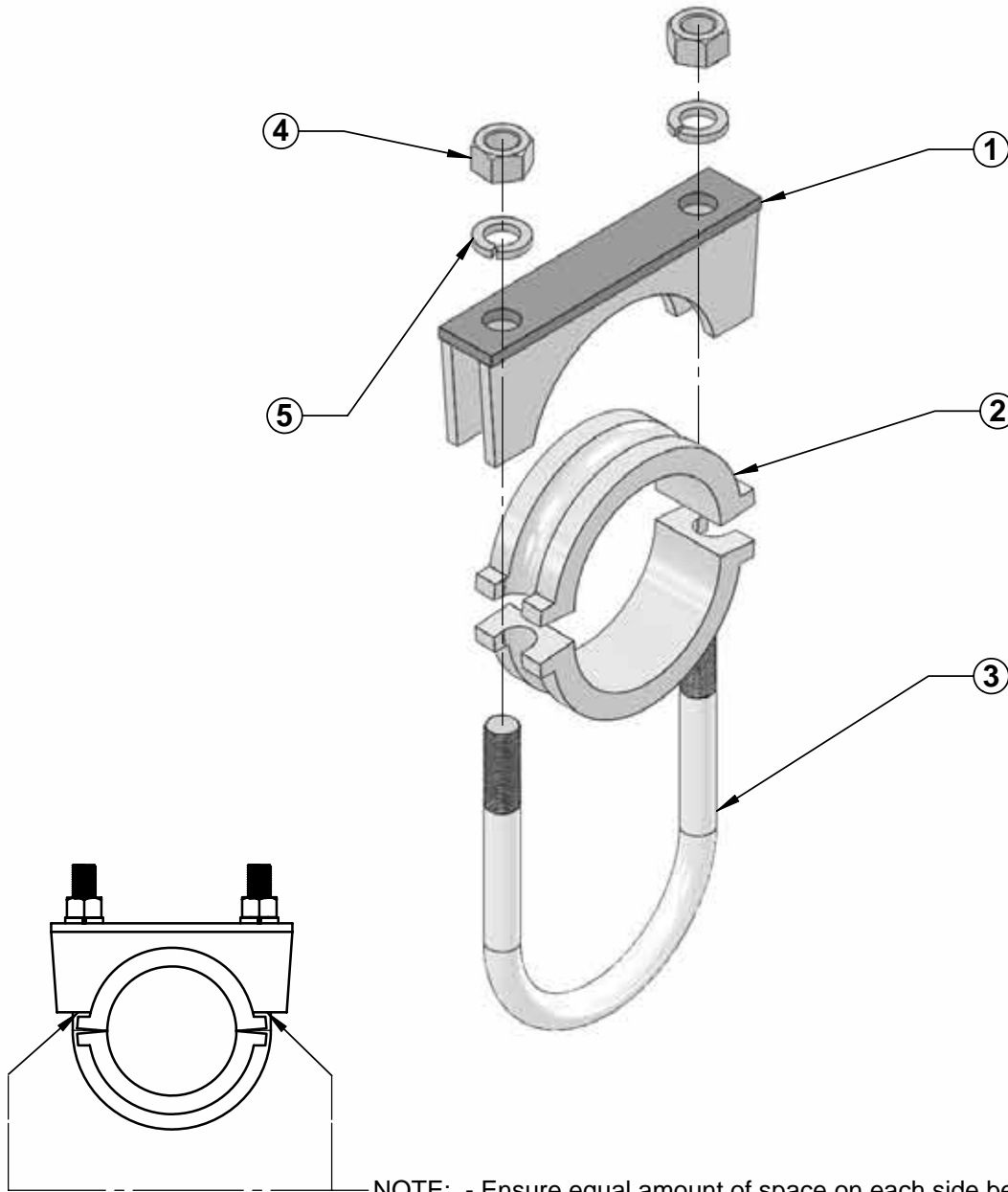

NOTE: - Ensure equal amount of space on each side before tightening U-Bolts .
 - Ensure equal number of threads on each side of U-Bolt.

<u>Ref No.</u>	<u>Part No.</u>	<u>Description</u>	<u>Qty.</u>
1.	SLL 1351	Bearing Cradle Cap Weldment	4
2.	SLL 1350	Bearing Cap Casting Machined	8
3.	UBNC16122R	1" Bearing U-bolt	4
4.	HXNUT-16NC	1" NC Hex Nut	8
5.	LWASHER-16	1" Lock Washer	8
	SLL 1352	U-Bolt Assembly (includes items 3, 4, and 5)	
	SLL 1353	Wheel Bearing Assembly (includes items 1, 2, 3, 4, and 5)	

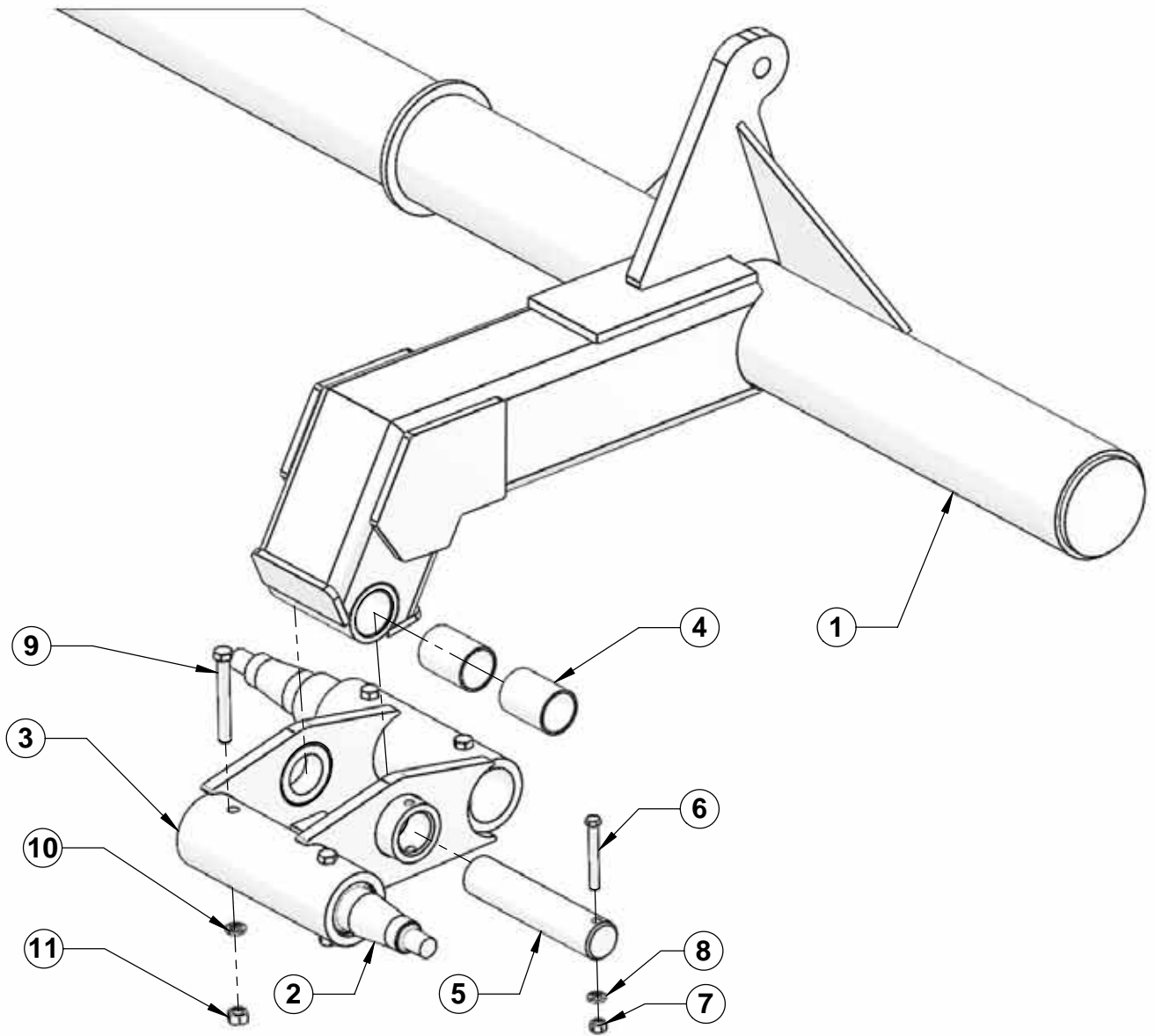

<u>Ref No.</u>	<u>Part No.</u>	<u>Description</u>	<u>24' Units</u>	<u>28' & 30' Units</u>
1.	FTB4-01M100	Tire Axle Weldment for 24' Units	1	
	FTB4-02M100	Tire Axle Weldment for 28' & 30' Units		1
2.	FTB4-00M300	Wheel Axle Spindle 2-3/4" Removable	4	6
3.	FTB4-00M200	Walking Beam Weldment	2	3
4.	GBR-3236G48	2" X 2-1/4" Self-Lubricating Bushings	8	12
5.	FTB4-00M206	Walking Beam Pivot Pin	2	3
6.	CSNC507056	7/16" X 3-1/2" NC Cap Screw Gr.5	2	3
7.	HXNUT-07NC	7/16" NC Hex Nut	2	3
8.	LWASHER-07	7/16" Lock Washer	2	3
9.	CSNC509072	9/16" X 4-1/2" NC Cap Screw Gr.5	8	12
10.	LWASHER-09	9/16" Lock Washer	8	12
11.	HXNUT-09NC	9/16" NC Hex Nut	8	12

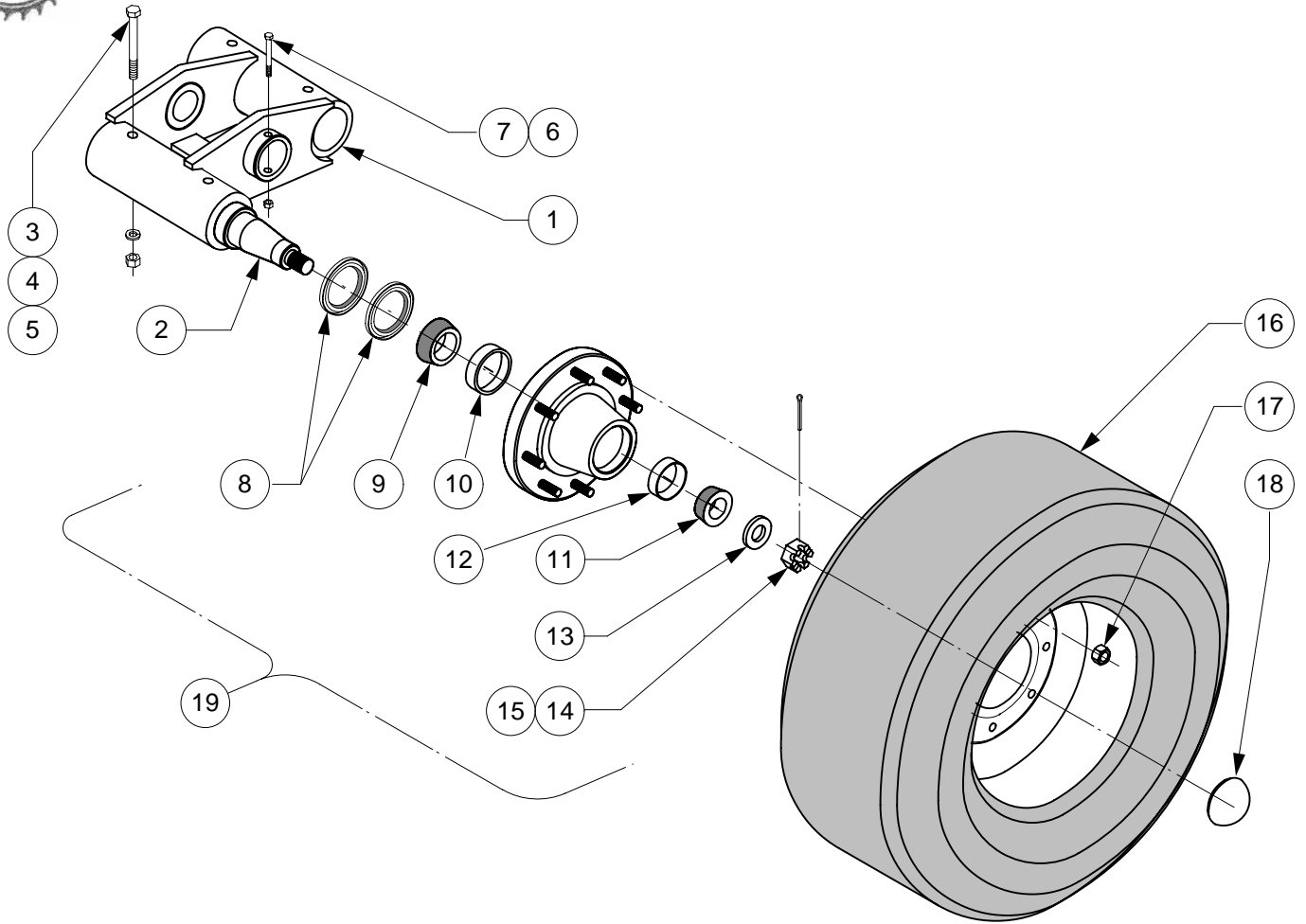

<u>Ref No.</u>	<u>New Part No.</u>	<u>Description</u>	<u>Qty./Unit</u>
1.	FTB4-00M200	Walking Beam Weldment	3
2.	FTB4-00M300	FTB4 Removable Spindle with holes	6
3.	CSNC509072	9/16" X 4-1/2" NC Cap Screw	12
4.	LWASHER-09	9/16" Lock Washer	12
5.	HXNUT-09NC	9/16" NC Hex Nut	12
6.	CSNC507056	7/16" X 3-1/2" NC Cap Screw	3
7.	HXNUT-07NC	7/16" NC Hex Nut	3
8.	GHB-8XXGSL	Grease Seal (2 per Hub required)	8
9.	GHB-8XXICN	Inner Bearing Cone for 8 on 8 XHVV Hub	4
10.	GHB-8XXIRC	Inner Bearing Cup for 8 on 8 XHVV Hub	4
11.	GHB-8XXOCN	Outer Bearing Cone for 8 on 8 XHVV Hub	4
12.	GHB-8XXORC	Outer Bearing Cup for 8 on 8 XHVV Hub	4
13.	GSP-16SPWA	1" Dia. Spindle Flat Washer	4
14.	GSP-16CANT	1" Dia. Spindle Castle Nut	4
15.	GPN-03X32C	3/16" x 2" Cotter Pin	4
16.	GWT-121614	12.5 X 16 14 Ply Tire with Wheel Assembly	6
17.	WHN-10NFWN	Hub Lug Nuts 5/8" NF for 8X8 XHVV Hub	32
18.	GHB-8XXCAP	Hub Cap	4
19.	GBH-8X8XHZ	8 on 8 XHVV Hub Ass'y w/ Bearings and 2 Grease Seals	4
	GWT-121614T	12.5 x 16 14 Ply Tire only	
	GWT-1216WH	16 X 10 Wheel	

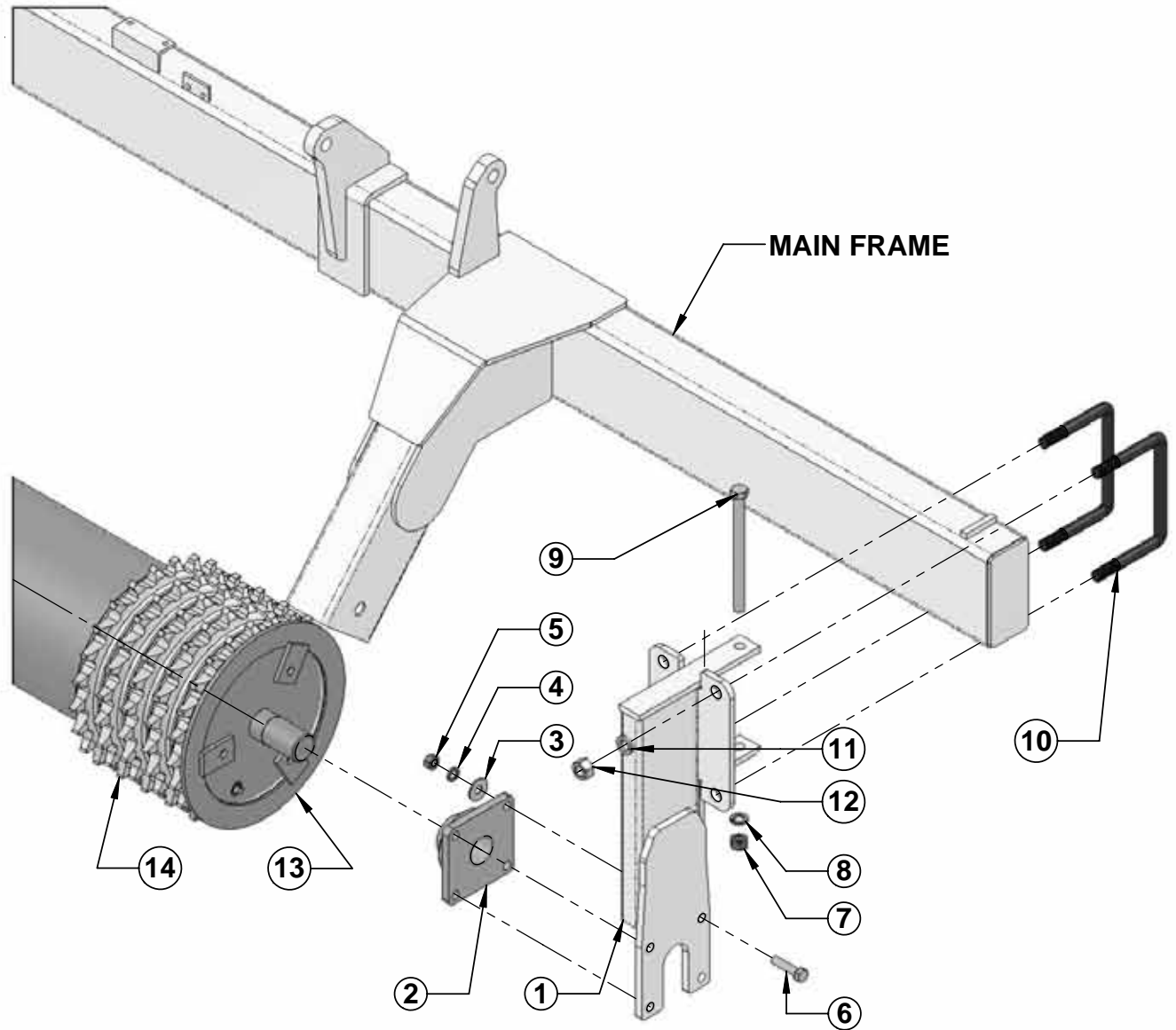

<u>Ref No.</u>	<u>Part No.</u>	<u>Description</u>	<u>Qty.</u>
1.	FTB4-00J100L(R)	Front Roller Arm Weldment LH and RH	2
2.	TPP3158	2-3/16" Flange Bearing	2 per roller
3.	FWASHER-10	5/8" Flat Washer	4 per bearing
4.	LWASHER-10	5/8" Lock Washer	4 per bearing
5.	HXNUT-10NC	5/8" NC Hex Nut	4 per bearing
6.	CSNC510040	5/8" X 2-1/2" NC Cap Screw Gr.5	4 per bearing
7.	HXNUT-12NC	3/4" NC Hex Nut	2 per roller
8.	LWASHER-12	3/4" Lock Washer	2 per roller
9.	CSNC512160	3/4" X 10" NC Cap Screw Gr.5	2 per roller
10.	UBNF14128S	7/8" NF Square U-Bolt	4 per roller
11.	LWASHER-14	7/8" Lock Washer	8 per roller
12.	HXNUT-14NF	7/8" NF Hex Nut	8 per roller
13.	see table p.7	Roller Retainer	2 per roller
14.	see table p.7	Roller Ring	varies

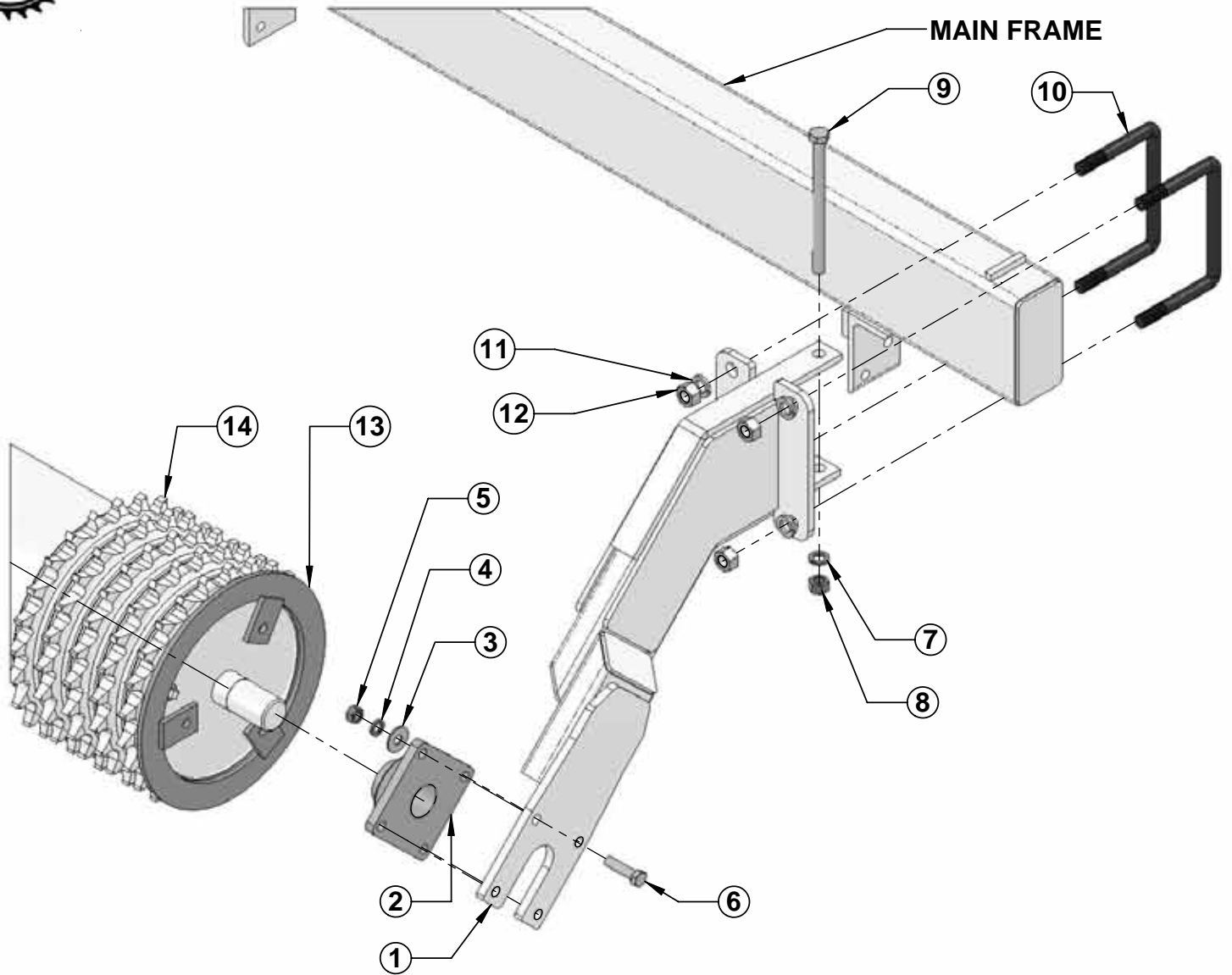

<u>Ref No.</u>	<u>Part No.</u>	<u>Description</u>	<u>Qty.</u>
1.	FTB4-00J000L(R)	Rear Roller Arm Weldment LH and RH	2
2.	TPP3158	2-3/16" Flange Bearing	2 per roller
3.	FWASHER-10	5/8" Flat Washer	4 per bearing
4.	LWASHER-10	5/8" Lock Washer	4 per bearing
5.	HXNUT-10NC	5/8" NC Hex Nut	4 per bearing
6.	CSNC510040	5/8" X 2-1/2" NC Cap Screw Gr.5	4 per bearing
7.	HXNUT-12NC	3/4" NC Hex Nut	2 per roller
8.	LWASHER-12	3/4" Lock Washer	2 per roller
9.	CSNC512160	3/4" X 10" NC Cap Screw Gr.5	2 per roller
10.	UBNF14128S	7/8" NF Square U-Bolt	4 per roller
11.	LWASHER-14	7/8" Lock Washer	8 per roller
12.	HXNUT-14NF	7/8" NF Hex Nut	8 per roller
13.	see table p.7	Roller Retainer	2 per roller
14.	see table p.7	Roller Ring	varies

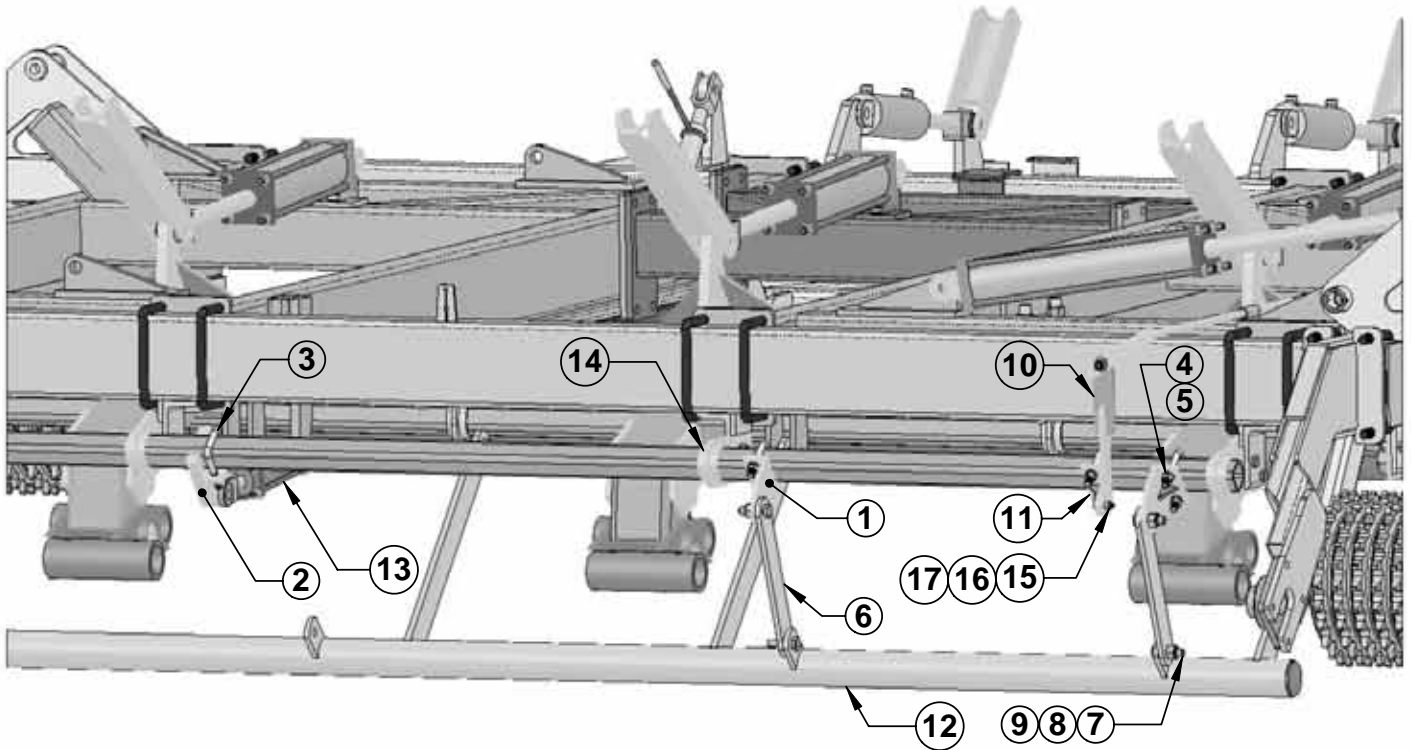

<u>Ref No.</u>	<u>Part No.</u>	<u>Description</u>	<u>Qty.</u>
1.	TBU-00L300	Linkage Clevis Plate Weldment	4
2.	TBU-00L400	Cylinder Anchor Weldment	1
3.	UBNC10X41S	5/8" NC Square Bend U-Bolt	5 per Lev. Pipe
4.	LWASHER-10	5/8" Lock Washer	10 per Lev. Pipe
5.	HXNUT-10NC	5/8" NC Hex Nut	10 per Lev. Pipe
6.	FTB-00Q500	Leveling Pipe Link for 12" Tube, 14/20 Rings	4
	TBU-00L500	Leveling Pipe Link for all other combinations	4
7.	CSNC512040	3/4" X 2-1/2" NC Cap Screw	8
8.	FWASHER-12	3/4" Flat Washer	4
9.	NYNUT-12NC	3/4" NC Nylon Lock Hex Nut	8
10.	FTB-00R100	Depth Indicator Link	1
11.	TBU-00R100	Depth Indicator Mount Plate Wldm	1
12.	FTB4-01P000	Main Frame Leveling Pipe Weldment for 24' Units	1
	FTB4-02P000	Main Frame Leveling Pipe Wldm. for 25' to 30' Units	1
13.	GHC-25080T	2-1/2" X 8" Tie Rod Hydraulic Cylinder	1
14.	TBU-00L200	TB Lift Axle Bracket Weldment	4
15.	CSNC508024	1/2" X 1-1/2" NC Cap Screw Gr.5	2
16.	FWASHER-08	1/2" Flat Washer	2
17.	NYNUT-08NC	1/2" NC Nylon Lock Hex Nut	2

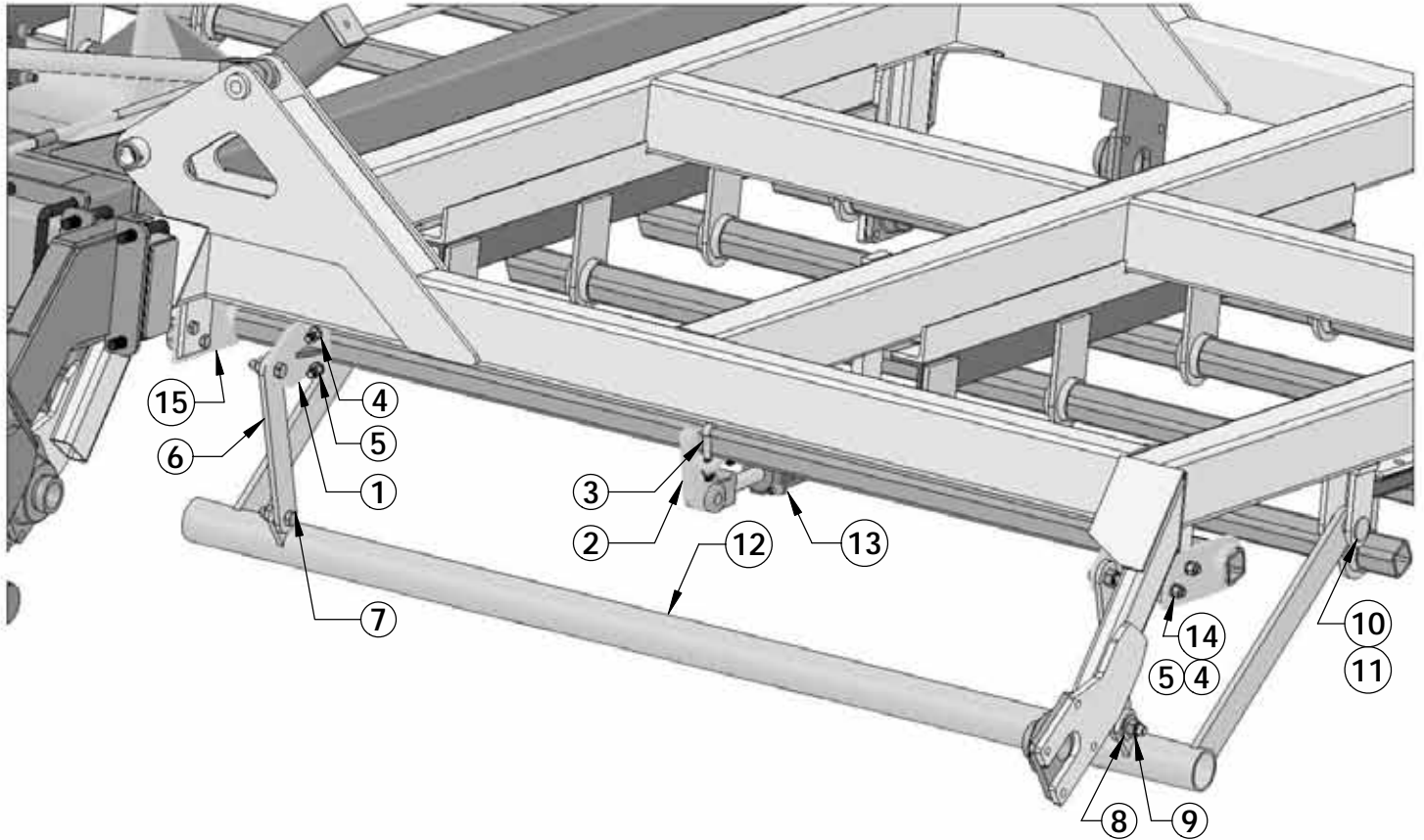

<u>Ref No.</u>	<u>Part No.</u>	<u>Description</u>	<u>Qty. per pair of wings</u>
1.	TBU-00L300	Linkage Clevis Plate Weldment	4
2.	TBU-00L400	Cylinder Anchor Weldment	2
3.	UBNC10X41S	5/8" NC Square Bend U-Bolt	6
4.	LWASHER-10	5/8" Lock Washer	20
5.	HXNUT-10NC	5/8" NC Hex Nut	20
6.	FTB-00Q500	Leveling Pipe Link for 12" Tube, 14/20 Rings	4
	TBU-00L500	Leveling Pipe Link for all other combinations	4
7.	CSNC512040	3/4" X 2-1/2" NC Cap Screw	8
8.	FWASHER-12	3/4" Flat Washer	4
9.	NYNUT-12NC	3/4" NC Nylon Lock Hex Nut	8
10.	GPN-16X068	1" X 4-1/4" Clevis Pin	4
11.	GPN-040LYN	1/4" Lynch Pin	4
12.	FTB4-24P100	Wing Leveling Pipe Weldment for 24' Units	2
	FTB4-28P100	Wing Leveling Pipe Wldm. for 28' Units	2
	FTB4-30P100	Wing Leveling Pipe Wldm. for 30' Units	2
13.	GHC-25080T	2-1/2" X 8" Tie Rod Hydraulic Cylinder	2
14.	CSNC510032	5/8" X 2" NC Cap Screw Gr.5	8
15.	TBU-00L200	TB Lift Axle Bracket Weldment	4



NOTE: FOR 24 FT. UNITS ONLY

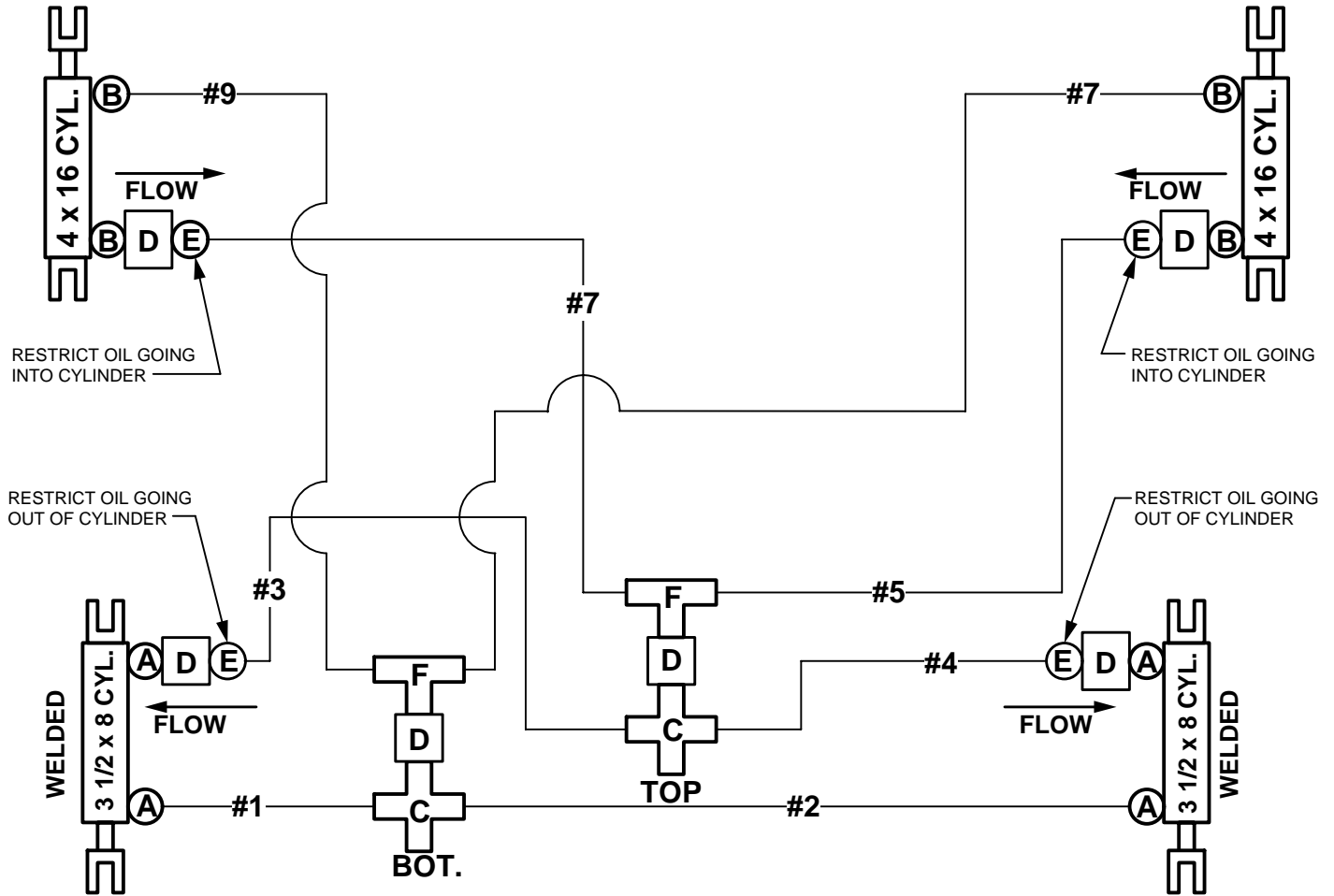

ALL HOSES ARE 8MP-8MP.

UNIT SIZE	24'	QTY.	FITTINGS	QTY.
HOSE #1	40"	1	(A) 8MP-8FPX 90° SWIVEL	4
HOSE #2	25"	1	(B) 8MB-8FPX 90° SWIVEL	4
HOSE #3	33"	1	(C) FP-8 CROSS FITTING	2
HOSE #4	18"	1	(D) 8MP-8MP NIPPLE	2
HOSE #5	64"	1	(E) PM-R-13 RESTRICTORS	5
HOSE #7	80"	2	(F) 8FPT TEE	2
HOSE #9	100"	1		



T. G. SCHMEISER CO., INC. HYDRAULIC DIA. FOR WHEEL AXLE AND PULL FRAME

NOTE: FOR 25 FT. THROUGH 30 FT. UNITS ONLY

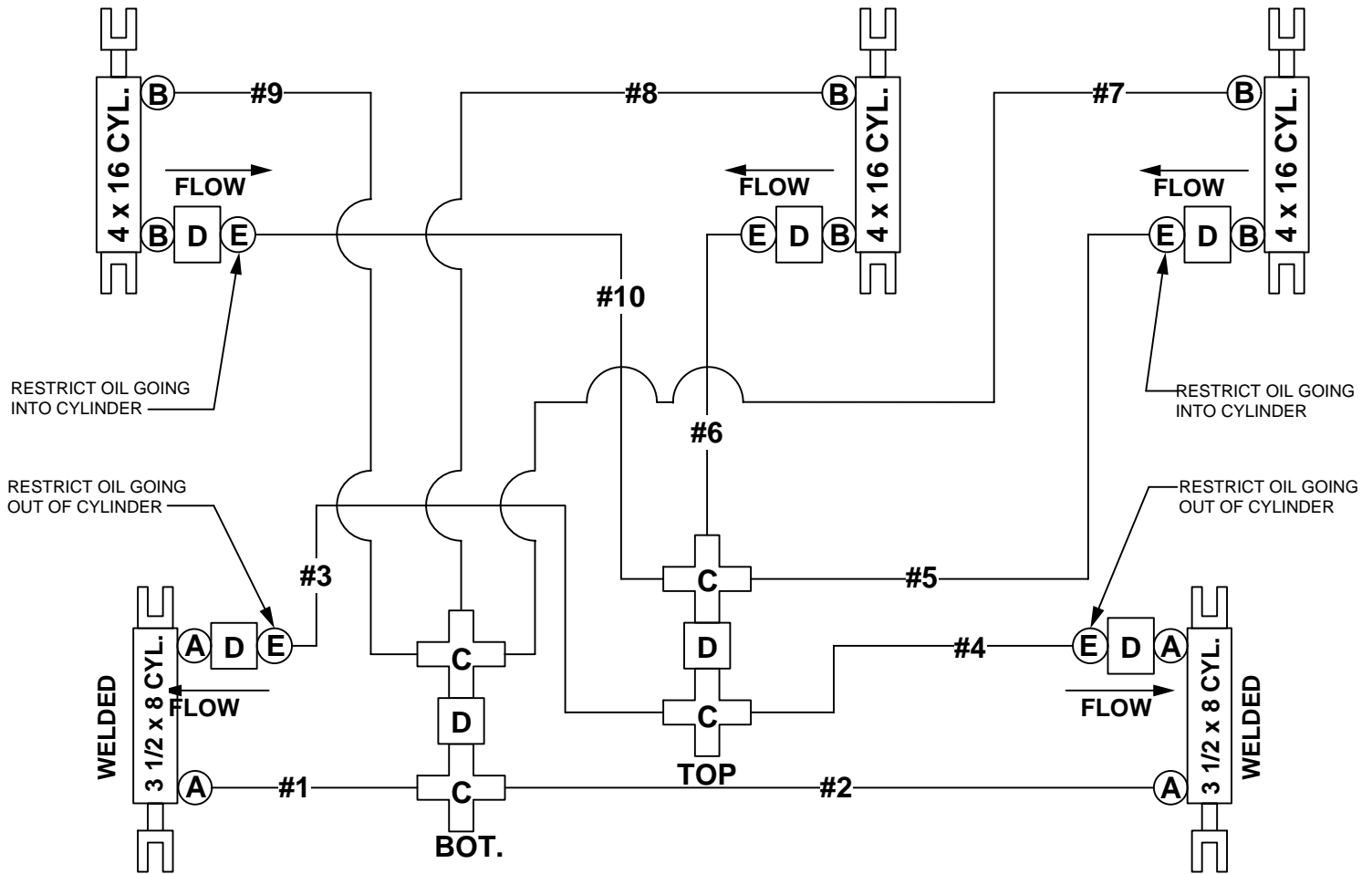

All hoses are 8MP-8MP

UNIT SIZE	25' through 30'	QTY.	FITTINGS	QTY.
HOSE #1	40"	1	(A) 8MP-8FPX 90° SWIVEL	4
HOSE #2	25"	1	(B) 8MB-8FPX 90° SWIVEL	6
HOSE #3	33"	1	(C) FP-8 CROSS FITTING	4
HOSE #4	18"	1	(D) 8MP-8MP NIPPLE	7
HOSE #5	76"	1	(E) PM-R-13 RESTRICTORS	5
HOSE #6	55"	1		
HOSE #7	83"	1		
HOSE #8	74"	1		
HOSE #9	116"	1		
HOSE #10	90"	1		



NOTE: FOR 24 FT. UNITS ONLY

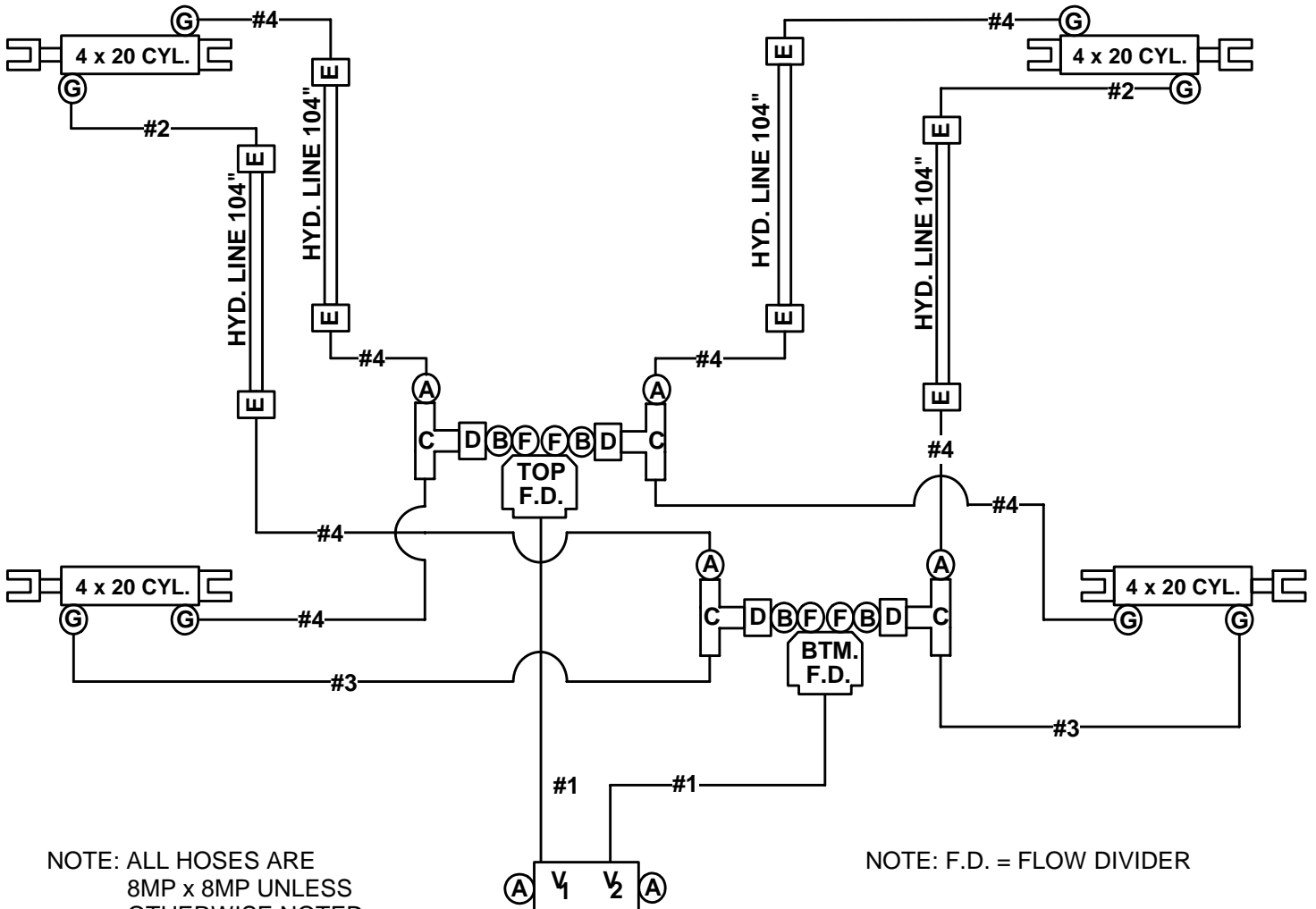

NOTE: ALL HOSES ARE
8MP x 8MP UNLESS
OTHERWISE NOTED

NOTE: F.D. = FLOW DIVIDER

COUNTER BALANCE
(1) YAC BODY "SUN"
(2) CBEA LAN CARTS

UNIT SIZE		24'	QTY.	FITTINGS	QTY.
HOSE #1	8MP-8MPX	13.5"	2	(A) 8MP-8FPX-90°	6
HOSE #2	8MP-8MP	49"	2	(B) 8MP-8FP-90°	4
HOSE #3	8MP-8MP	60"	2	(C) 8FP TEE	4
HOSE #4	8MP-8MP	33"	8	(D) 8MP NIPPLE	4
				(E) 8FP COUPLING	8
				(F) 8MP-8FPX COUPLING	4
				(G) 8MB-8FPX-90°	8



NOTE: FOR 25 FT. THROUGH 30 FT. UNITS ONLY

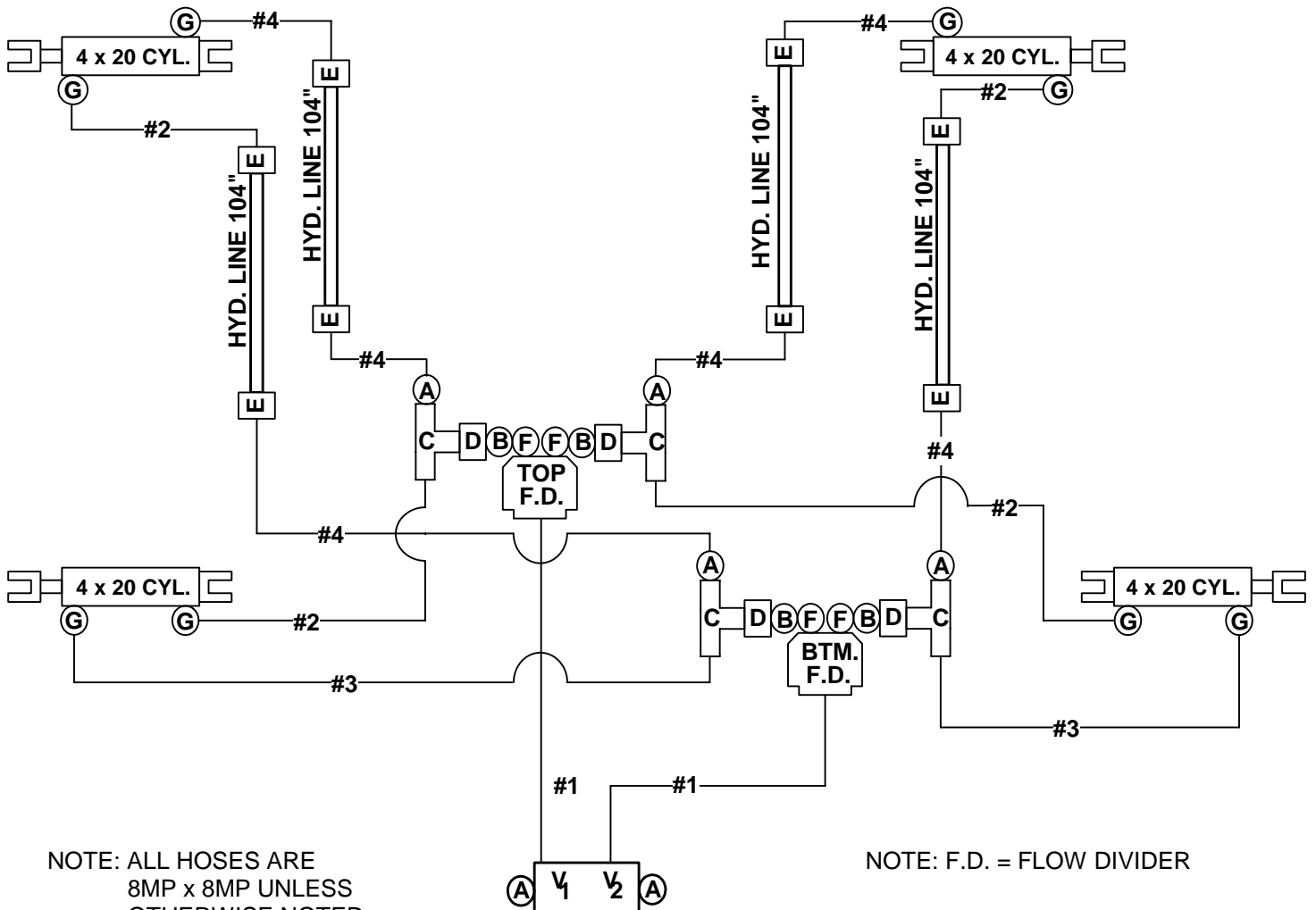

NOTE: ALL HOSES ARE
8MP x 8MP UNLESS
OTHERWISE NOTED

NOTE: F.D. = FLOW DIVIDER

COUNTER BALANCE
(1) YAC BODY "SUN"
(2) CBEA LAN CARTS

UNIT SIZE		25' through 30'	QTY.	FITTINGS	QTY.
HOSE #1	8MP-8MPX	13.5"	2	(A) 8MP-8FPX-90°	6
HOSE #2	8MP-8MP	49"	4	(B) 8MP-8FP-90°	4
HOSE #3	8MP-8MP	75"	2	(C) 8FP TEE	4
HOSE #4	8MP-8MP	33"	6	(D) 8MP NIPPLE	4
				(E) 8FP COUPLING	8
				(F) 8MP-8FPX COUPLING	4
				(G) 8MB-8FPX-90°	8

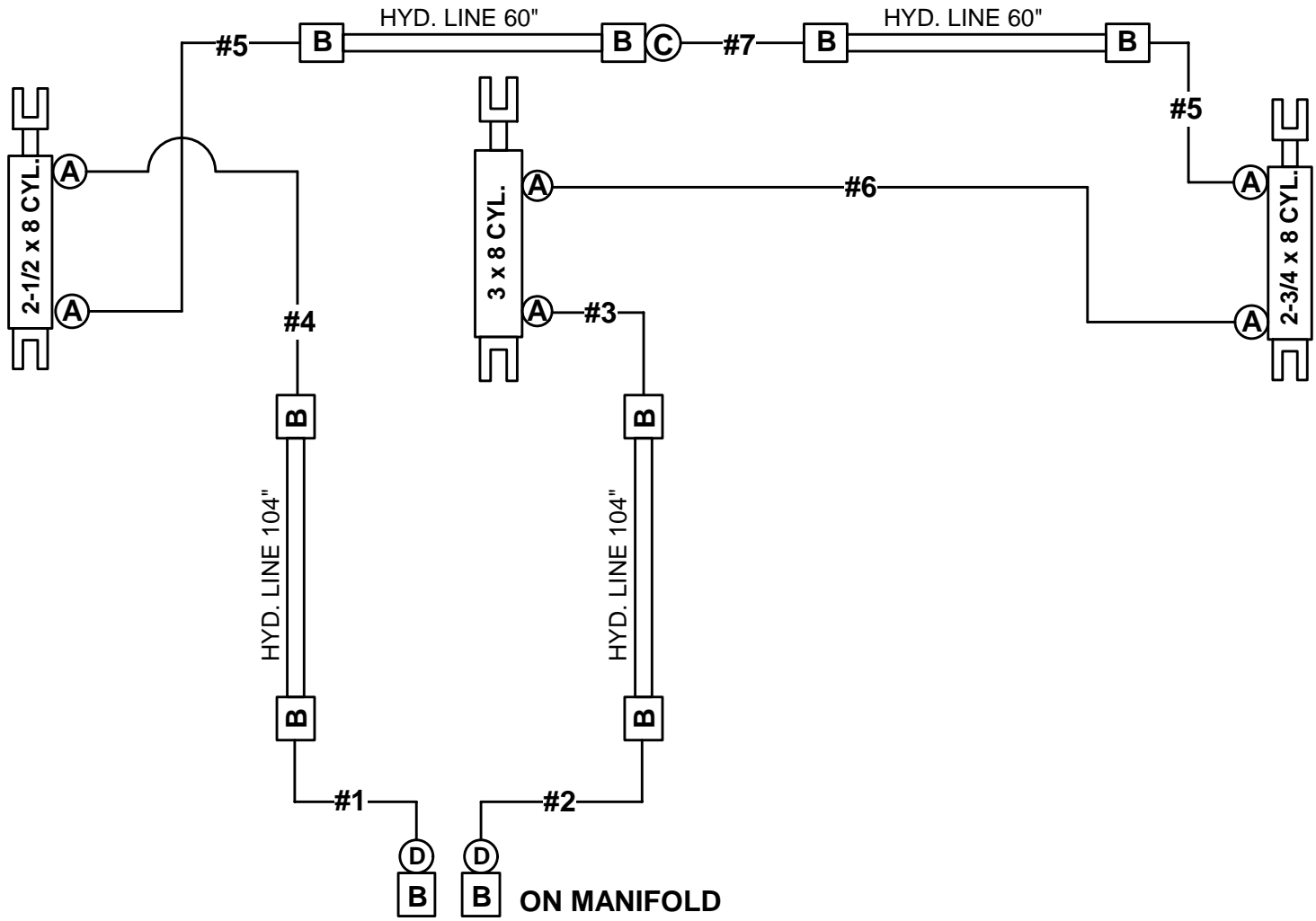

HOSES :		24'	25' & 26'	28' & 30'
(1) # 1	8MP-8MP	55"	55"	55"
(1) # 2	8MP-8MP	40"	40"	40"
(1) # 3	8MP-8MP	33"	33"	33"
(1) # 4	8MP-8MP	122"	125"	139"
(2) # 5	8MP-8MP	72"	72"	80"
(1) # 6	8MP-8MP	134"	139"	145"
(1) # 7	8MP-8MP	30"	49"	49"

FITTINGS :	QTY.
(A) 8MB-8FPX-90°	6
(B) 8FP COUPLINGS	8
(C) 8MP-8FPX STRAIGHT	1
(D) 8MP-8FPX-90°	2

T.G. SCHMEISER CO., INC.®

Limited Warranty Statement

T. G. Schmeiser Co., Inc. warrants each new Schmeiser® product to be free from defects in material and workmanship. This warranty is applicable only for the normal service life expectancy of the product or components, not to exceed twelve (12) consecutive months from the date of delivery of the new Schmeiser product to the original purchaser.

Genuine T. G. Schmeiser Co., Inc. replacement parts and components will be warranted for 90 days from date of purchase, or the remainder of the original equipment warranty period, whichever is longer.

Under no circumstances will it cover any merchandise or components thereof, which, in the opinion of the company, has been subjected to misuse, unauthorized modifications, alteration, an accident or if repairs have been made with parts other than those obtainable through T. G. Schmeiser Co., Inc.

The Company in no way warrants engines, batteries, cylinders, tires or other trade accessories since these items are warranted separately by their respective manufacturer. Expendable components such as points, shanks, blades, rings, bearings, teeth, and the like are excluded from this warranty.

Our obligation under this warranty shall be limited to repairing or replacing, free of charge to the original purchaser, any part that, in our judgment, shall show evidence of such defect, provided further that such part shall be returned within thirty (30) days from date of failure to T. G. Schmeiser Co., Inc., routed through the dealer and distributor from whom the purchase was made, transportation charges prepaid.

This warranty shall not be interpreted to render T. G. Schmeiser Co., Inc. liable for injury or damages of any kind or nature to person or property. This warranty does not extend to the loss of crops, loss because of delay in harvesting, or any expense or loss incurred for labor, substitute machinery, rental or for any other reason.

Except as set forth above, **T. G. Schmeiser Co., Inc. shall have no obligation or liability of any kind on account of any of its equipment and shall not be liable for special or consequential damages. T. G. Schmeiser Co., Inc. makes no other warranty, expressed or implied, and, specifically, T. G. Schmeiser Co., Inc. disclaims any implied warranty or merchantability or fitness for a particular purpose. Some states or provinces do not permit limitations or exclusions of implied warranties or incidental or consequential damages, so the limitations or exclusion in this warranty may not apply.**

This warranty is subject to any existing conditions of supply, which may directly affect our ability to obtain materials or manufacture replacement parts.

T. G. Schmeiser Co., Inc. reserves the right to make improvements in design or changes in specifications at any time, without incurring any obligation to owners of units previously sold.

No one is authorized to alter, modify or enlarge this warranty nor the exclusion, limitations and reservations.

**WARRANTY VOID IF NOT REGISTERED
WITHIN 30 DAYS OF PURCHASE DATE**

